

M29504 /4 & /5 Fiber Optic Termini

AmphenolFSI

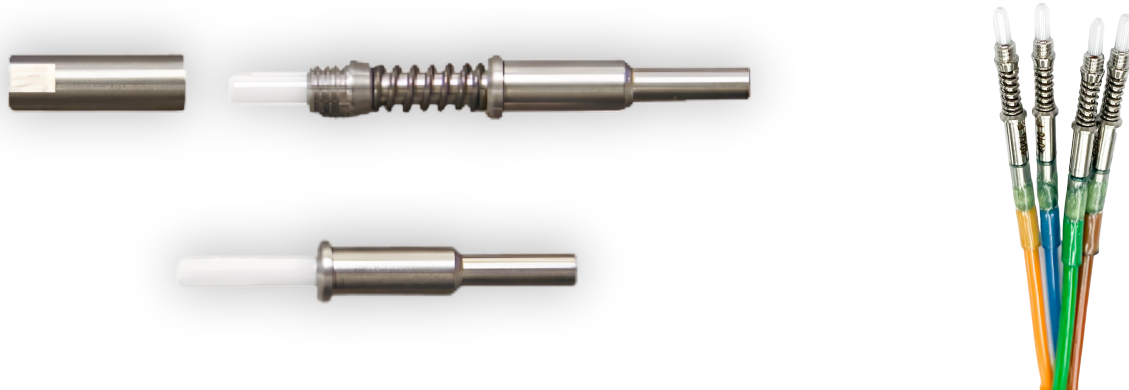

AFSI's M29504 /4 & /5 style fiber optic termini, M29K1000 and M29L1000 series, provide superior optical and mechanical performance.

Designed to fit into MIL-DTL-38999 Series III, pin size 16 connectors, this low-cost, high-precision terminus family is ideal for harsh environment fiber optic interconnections.

Available for single mode and multimode applications, these termini conform to the rigorous conditions of the MIL-PRF-29504B specification.

The M29K1000 and M29L1000 series termini utilize the highest quality zirconia ceramic ferrules and split alignment sleeves available. AFSI's tight-tolerance ferrules are optimized for low insertion loss, low back reflection and exceptional durability. All ferrules are available in standard and ultra polished end faces for those tight optical budget applications. In addition, epoxy removal and polishing times are minimized by the ferrule's pre-domed design feature.

The M29L1000's zirconia split alignment sleeve design ensures accurate physical contact, fiber-to-fiber alignment and guarantees the highest performing connector of its kind for use in a variety of demanding environmental conditions. The M29K1000 and M29L1000 series fiber optic termination system offers precise, superior and reliable connections over repeated connector mating cycles and through a wide range of harsh environmental conditions.

Features:

- Precision fiber optic ceramic ferrules
- Pre-radius ferrule design
- Precision "press fit" stainless steel design
- Accurate ferrule alignment system
- Size 16 design (MIL-DTL-38999 compatible)
- Low insertion loss and back reflection
- Designed and manufactured to MIL-PRF-29504 /4 and /5 specifications

Applications:

- Avionics
- NAVAIR
- Commercial Aircraft
- Harsh Environment
- Land Tactical Applications
- Shipboard

Benefits:

- Solid reliable connectivity through a wide range of harsh environmental conditions
- Compatible with all qualified MIL-DTL-38999, Series III connectors
- Fast termination and polish time
- Reliable, repeatable and durable connections
- Easy to clean

Amphenol Fiber Systems International, Inc.

859 State Highway 121, BLDG 2 | Allen, TX 75013 | (214) 547-2400 | sales@fibersystems.com | www.fibersystems.com

Amphenol Fiber Systems International (AFSI), a division of Amphenol Military & Aerospace Operations (AMAO), is the largest manufacturer of harsh environment fiber optic cable assemblies & connectors in the world.

M29504 /4 & /5 Fiber Optic Termini



PIN Assembly:

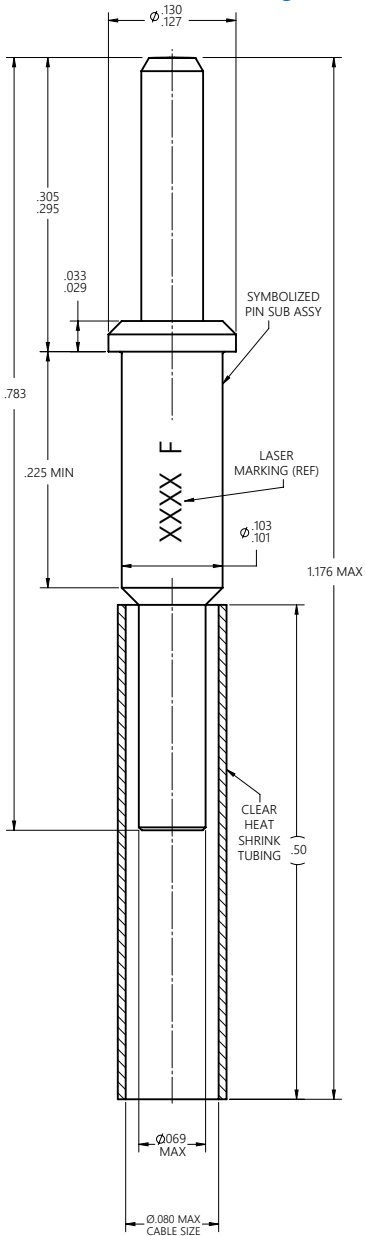

Specifications:

Specification	Measurement / Detail
Back Reflection	Better than -40dB - PC polish Better than -50dB - enhanced PC polish
Insertion Loss	0.45 typical (measured with 62.5/ 125mm fiber @1310nm)
Operating Temperature	-65°C to +150°C
Temperature Life	150°C for 1000 hours
Vibration	40G random
Mechanical Shock	500G
Mating Durability	500 cycles
Cable Retention Force	25lbs (dependent on cable construction)

Socket Assembly:

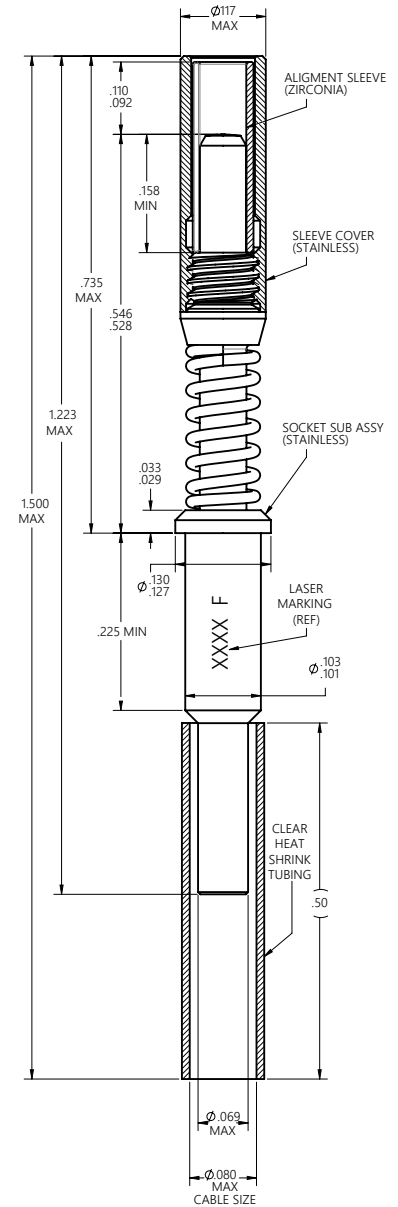

M29504/4 (PIN) Fiber Size Table:

AFSI PN	Ferrule ID	Reference Only M29504/4-XXXX
M29K1000	.127 + .002	M29504/4-4040
M29K1001	.126 + .002	M29504/4-4210
M29K2000	.126 + .001	M29504/4-4209
M29K5000	.156 + .003	M29504/4-4211
M29K5001	.157 + .003	M29504/4-4212

M29504/5 (Socket) Fiber Size Table:

AFSI PN	Ferrule ID	Reference Only M29504/5-XXXX
M29L1000	.127 + .002	M29504/5-4046
M29L1001	.126 + .002	M29504/5-4239
M29L2000	.126 + .001	M29504/5-4238
M29L5000	.156 + .003	M29504/5-4240
M29L5001	.157 + .003	M29504/5-4241

M29504 /4 & /5

Fiber Optic Termini

AmphenolFSI

COTS Socket Ordering Table:

AFSI PN	Ferrule ID	Reference Only M29504/5-XXXX
C29L1000	.127 + .002	M29504/5-4046
C29L1001	.126 + .002	M29504/5-4239
C29L2000	.126 + .001	M29504/5-4238
C29L2001	.1253 + .001	M29504/5-4236
C29L2002	.1255 + .001	M29504/5-4237
C29L3000	.142 + .003	M29504/5-4249
C29L3001	.145 + .003	M29504/5-4250
C29L5000	.156 + .003	M29504/5-4240
C29L5001	.157 + .003	M29504/5-4241
C29L6000	.173 + .003	M29504/5-4088
C29L6001	.175 + .003	M29504/5-4242
C29L8000	.236 + .004	M29504/5-4243
C29L8050	.286 + .004	M29504/5-4244
C29L9000	.448 + .004	M29504/5-4245

COTS Pin Ordering Table:

AFSI PN	Ferrule ID	Reference Only M29504/4-XXXX
C29K1000	.127 + .002	M29504/4-4040
C29K1001	.126 + .002	M29504/4-4210
C29K2000	.126 + .001	M29504/4-4209
C29K2001	.1253 + .001	M29504/4-4207
C29K2002	.1255 + .001	M29504/4-4208
C29K3000	.142 + .003	M29504/4-4243
C29K3001	.145 + .003	M29504/4-4244
C29K5000	.156 + .003	M29504/4-4211
C29K5001	.157 + .003	M29504/4-4212
C29K6000	.173 + .003	M29504/4-4087
C29K6001	.175 + .003	M29504/4-4213
C29K8000	.236 + .004	M29504/4-4214
C29K8050	.286 + .004	M29504/4-4215
C29K9000	.448 + .004	M29504/4-4216

Amphenol Fiber Systems International (AFSI) manufactures a complete line of next generation fiber optic termini that are used in 38999 style connectors for harsh environment applications. AFSI has MIL Qualified (QPL) and COTS (Commercial Off The Shelf) available to meet the needs of all applications.

About AFSI:

Amphenol Fiber Systems International (AFSI) designs, manufactures, markets and supports the broadest portfolio of reliable and innovative fiber optic interconnect solutions to withstand the harsh environments of military, aerospace, heavy industrial, broadcast and medical applications. Since inception in 1993, AFSI continues to advance its position as a global leader in harsh environment fiber optic interconnect.

AFSI has delivered millions of fiber optic solutions in more than 30 countries. Whenever there is a need for superior, cost-effective fiber optic systems to withstand the harshest of operating environments, you can rely on AFSI for engineering know-how, top-quality products and expert technical support.

Visit www.fibersystems.com for more information.

For more information on how to order or to obtain a price quote on our products, call toll free (U.S. only) at 800.472.4225, international calls please use 1.214.547.2400 or e-mail info@fibersystems.com.

Amphenol Fiber Systems International, Inc.

859 State Highway 121, BLDG 2 | Allen, TX 75013 | (214) 547-2400 | sales@fibersystems.com | www.fibersystems.com

Amphenol Fiber Systems International (AFSI), a division of Amphenol Military & Aerospace Operations (AMAO), is the largest manufacturer of harsh environment fiber optic cable assemblies & connectors in the world.