

TACBeam®

M83526/20 & /21 Qualified Expanded Beam
Rugged Fiber Connectors



The TACBeam® is a MIL-PRF-83526/20 & /21 qualified expanded beam rugged fiber optic connector for military and industrial applications.

TACBeam® is hermaphroditic, which allows multiple cable assemblies to connect together to support varying distance requirements. The TACBeam® connectors are available in both multimode and single mode, can support 2, 4, 8 or 12 channels using a common insert and will accept a wide variety of cables for any application. Sub-micron machining and measuring equipment is in the Amphenol Fiber Systems International (AFSI) facility for the manufacturing of this new expanded beam product.

AFSI designs, manufactures, markets and supports reliable and innovative fiber optic interconnect solutions that withstand the harsh environments of military, oil & gas, mining and broadcast applications. After more than two decades in business, AFSI continues to uphold its position as a global leader in fiber optic interconnect components and systems such as termini, M28876, MIL-ST, TFOCA and the TFOCA-II® connector, which AFSI developed and patented.

Features & Benefits:

- **QPL Qualified**
 - M83526/20 & /21 qualified
- **Mechanical**
 - Hermaphroditic coupling
 - Enables 'daisy-chaining' assemblies supporting varying distances
- **Single Mode and Multimode**
 - The only dual wavelength qualified connector
- **Expanded Beam**
 - Less susceptible to contaminants affecting optical performance
- **Environmental**
 - Operating temperature -46°C to + 71°C
 - 15 m water depth-mated
 - 3000 cycles mating durability
- **ROHS Compliant**
 - Hard black anodized aluminum
 - Cadmium free
 - Marine bronze & stainless steel available

Amphenol Fiber Systems International, Inc.

859 State Highway 121, BLDG 2 | Allen, TX 75013 | (214) 547-2400 | sales@fibersystems.com | www.fibersystems.com

Amphenol Fiber Systems International (AFSI), a division of Amphenol Military & Aerospace Operations (AMAO), is the largest manufacturer of harsh environment fiber optic cable assemblies & connectors in the world. Visit AMAO at amphenolmao.com

TACBeam[®] M83526/20 & /21 Qualified Expanded Beam Rugged Fiber Connectors

Applications:

- C4ISR Tactical Military Ground Communications
- Oil & Gas Seismic Systems
- Broadcast Systems
- Mining and Tunneling Equipment

Assembly Tooling:

No specific tooling is required for the termination of this product

Performance:

Requirement	Result
Insertion Loss, Typical	1.5 dB Multimode @ 850/1300 nm, 0.7 dB Typical 2.5 dB Single Mode @ 1310/1550 nm, 1.0 Typical
Return Loss	>34 dB unmated @ 1310/1550 nm
Mating Durability	3,000 cycles
Operating Temperature	-46°C to 71°C
Storage Temperature	-57°C to 85°C
Cyclic Temperature	-55°C/85°C
Humidity	95% RH
Immersion	15 m, water (plug & receptacle)
Shock	EIA/TIA 455-14, test condition A
Impact	EIA/TIA 455-2, method C, service class: Severe
Vibration	EIA/TIA 455-11, sinusoidal condition III (at 10 g), random condition VI (letter C) for 1.5 hours
Weight	Approximately 130 g plug & 100 g receptacle

EB4H1000: Plug

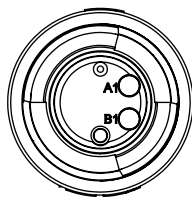
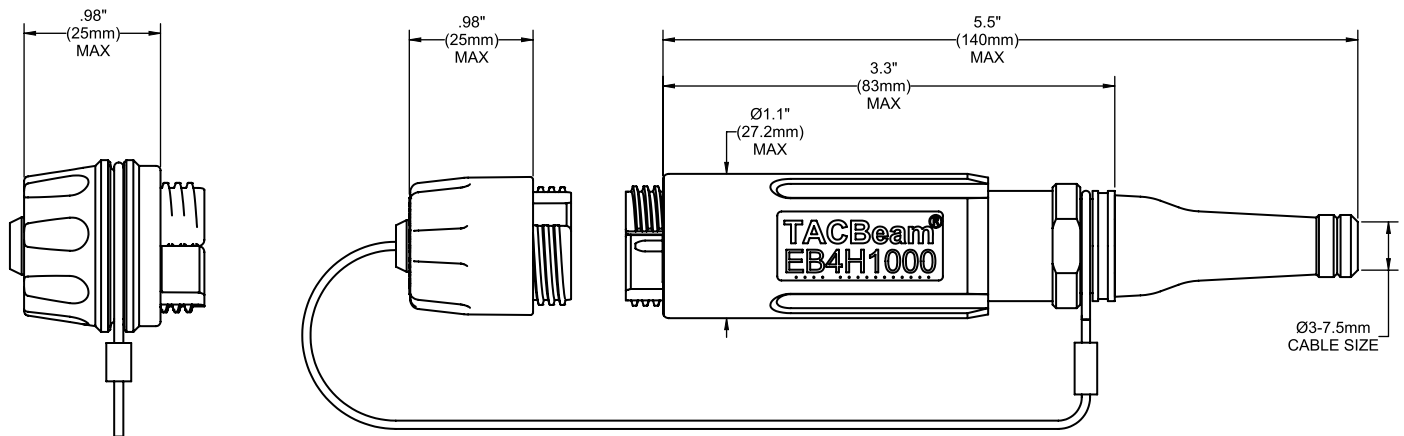

2 CH

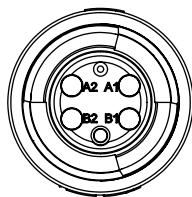

4 CH

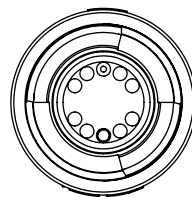

8 CH

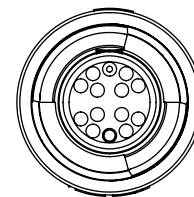

12 CH

EB4H6000: Wall Mount Receptacle

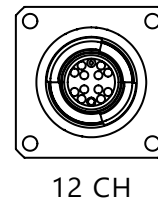
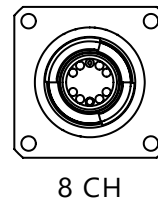
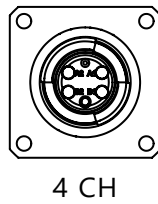
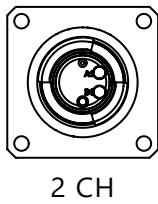
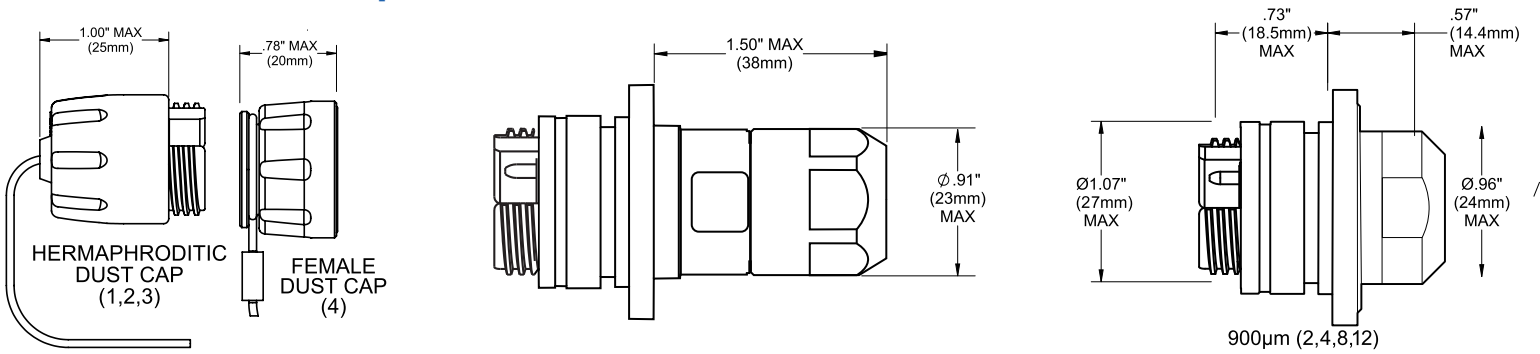

EB4H8000: Jam Nut Receptacle

