

TFOCA-II 4 Channel Fiber Optic Connectors



AFSI designed its patented TFOCA-II® connectors to survive the harshest battlefield conditions imaginable.

The heart of the TFOCA-II® family of deployable fiber optic connectors centers on the TFOCA-II® sealed free-floating termini. The robust termini design enables TFOCA-II® connectors to seal against high humidity and moisture conditions while allowing full axial and orbital movement of the mated termini, providing low insertion loss and minimal back reflection.

The US ARMY WIN-T program selected TFOCA-II® as the standard “next generation” fiber optic connector for military tactical deployable networks. The AFSI TFOCA-II® has also been adopted as the baseline design that DSCC (Defense Supply Center, Columbus) is utilizing in drafting the MILDTL- 83526/16 and/17 connector specifications.

Features & Benefits :

- **Hermaphroditic Design for Versatility** - Enables multiple TFOCA-II® plug assemblies to be concatenated.
- **Removable End Cap** - Allows for easy field maintenance and cleaning.
- **4-Channel Connector Design** - Two fold channel increase over TFOCA with better optical performance.
- **Improved Cable Retention Strength** - Designed to meet 400lb. pull strength while protecting fibers from stress.
- **Zn-Ni Plating** - Provides substantial longevity to corrosive environments. Meets new mandate set by the Environmental Protection Agency for elimination of heavy metal plating.
- **Commercial Ceramic Ferrule Technology** - Enables TFOCA-II® connector to provision multimode and single mode interconnect with a variety of polishes including SPC and UPC.
- **Solid Core Alignment Sleeves** - More robust than split alignment sleeves.
- **Hermaphroditic Dust Cap** - Plug and/or receptacle dust caps connect together to prevent dust and moisture penetration during deployment.
- **Optional Key Positions** - Four key positions (1,2,3, universal) available, enabling segregation of mated plug/receptacles or plug/plug, through mechanical interface.
- **Field Repairable Using Existing Parts** - Additional connector components (other than termini) are not required to perform field repair.
- **Also Available in Stainless Steel and Brass** - Allows the connector to be used in a variety of applications.

Amphenol Fiber Systems International, Inc. | 1300 Central Expressway N, Suite 100 Allen, TX 75013

Phone: (214) 547-2400 | Email: sales@fibersystems.com | Website: amphenol-fsi.com

Amphenol Fiber Systems International (AFSI), a division of Amphenol Military & Aerospace Operations (AMAO), is the largest manufacturer of harsh environment fiber optic cable assemblies & connectors in the world. Visit AMAO at amphenolmao.com.

TFOCA-II® 4 Channel Hermaphroditic Plug :

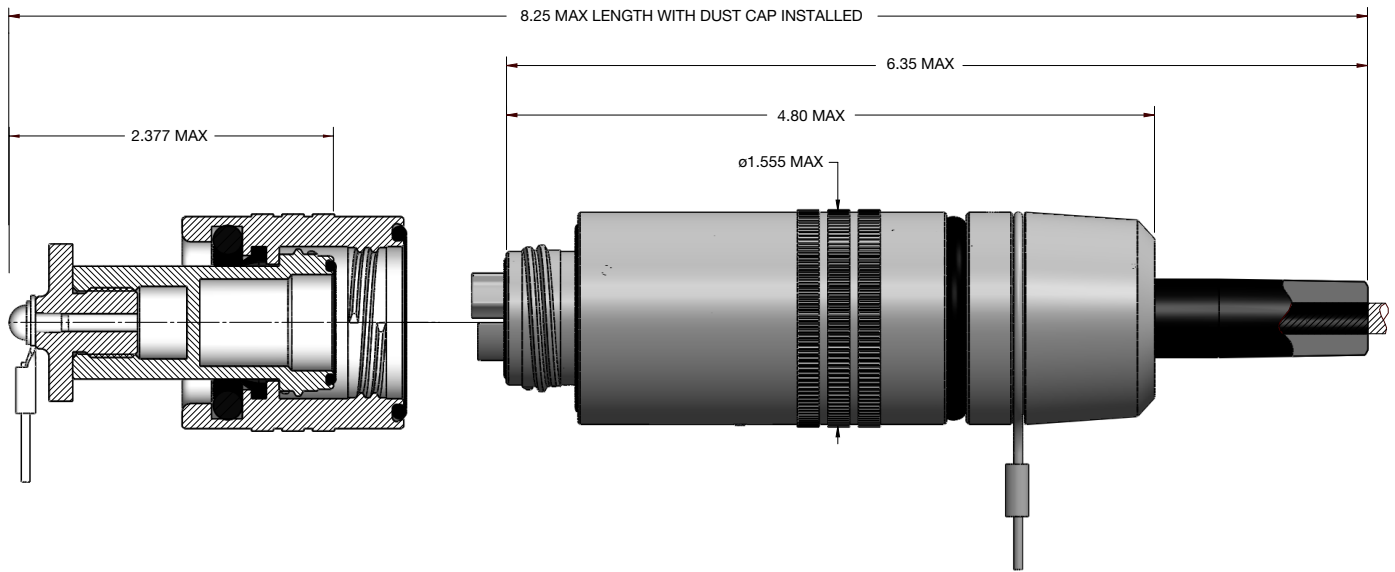

7)2 4 Channel 90° Plug :

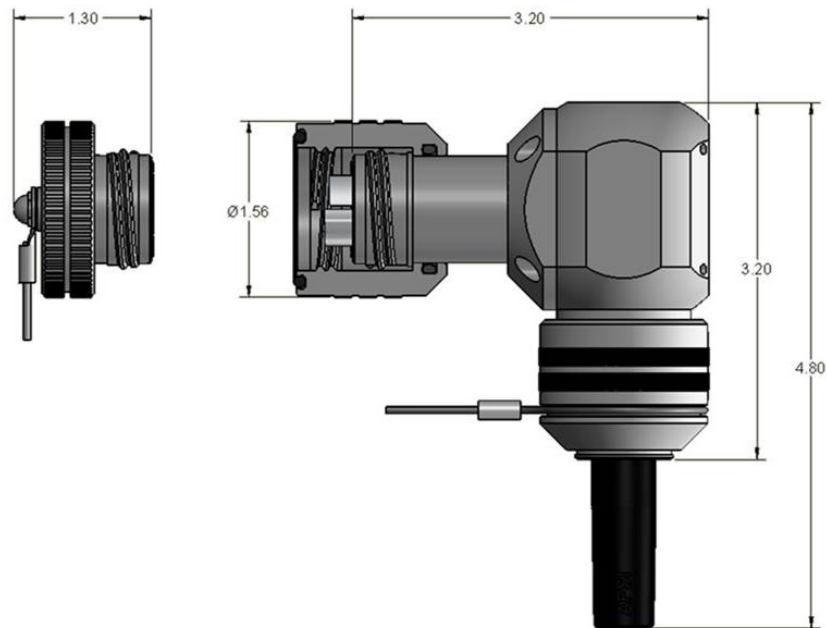

Amphenol Fiber Systems International (AFSI) :



Amphenol Fiber Systems International (AFSI) designs, manufactures, markets and supports reliable and innovative fiber optic interconnect solutions that withstand the harsh environments of military, oil & gas, mining and broadcast applications. After more than 2 decades in business, AFSI continues to uphold its position as a global leader in fiber optic interconnect components and systems such as termini, M28876, MIL-ST, TFOCA and the TFOCA-II® connector, which AFSI developed and patented.

AFSI has delivered millions of fiber optic connectors in more than 34 countries. Whenever there is a need for superior, cost-effective fiber optic systems and products that will stand up to demanding operating environments, you can rely on AFSI for engineering know-how, top-quality products and expert technical support.

Visit www.fibersystems.com for more information.

How to Order :

For more information on how to order or to obtain a price quote on our TFOCA-II® 4 Channel products, call toll free (U.S. only) at 800.472.4225, international calls please use 1.214.547.2400 or e-mail info@fibersystems.com.