

Amphenol FSI mTACH Mini 2-Channel Connector

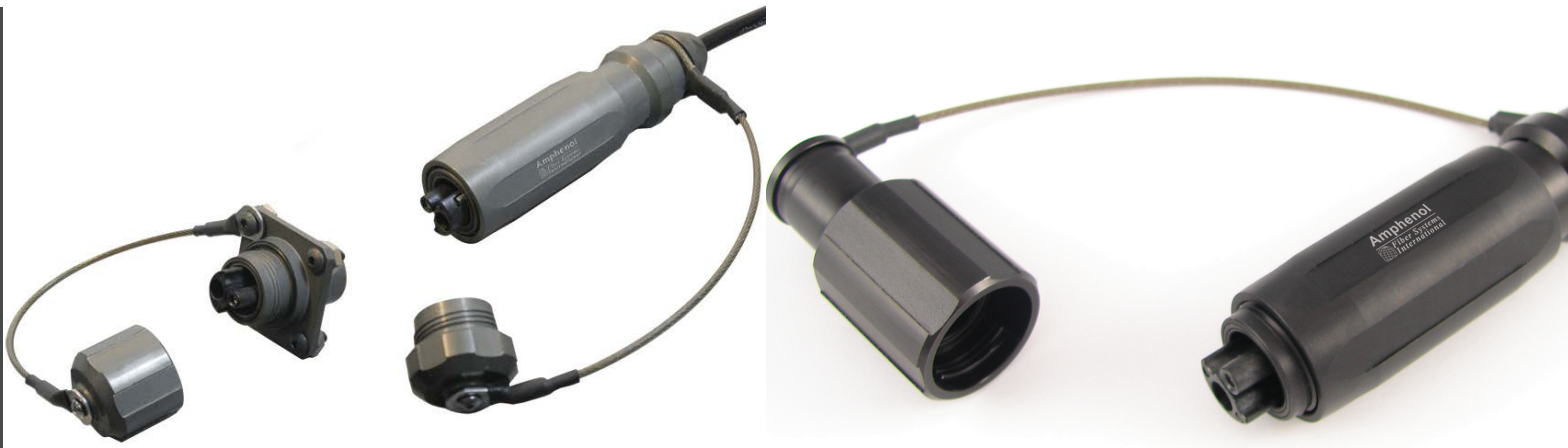

Amphenol Fiber Systems International (AFSI) manufactures a complete line of next generation fiber optic connectors designed to meet the needs of harsh environment applications.

Amphenol Fiber Systems International (AFSI) offers a high-performance, dual-channel hermaphroditic fiber optic connector, ideally suited for the energy, broadcast, and military markets. The mTACH connector is rugged yet compact. It is designed for use in tight spaces yet durable enough for use in applications requiring multiple mating cycles and harsh environments.

Features & Benefits :

- Hermaphroditic design facilitates concatenation
- Single mode and multi-mode versions
- Compact size
- Multiple finishes and materials available
- RoHS compliant
- Environmentally sealed
- 2000 mating cycles durability
- Removable insert cap to allow easy cleaning
- >400 pull strength

mTACH6000 Product Drawing:

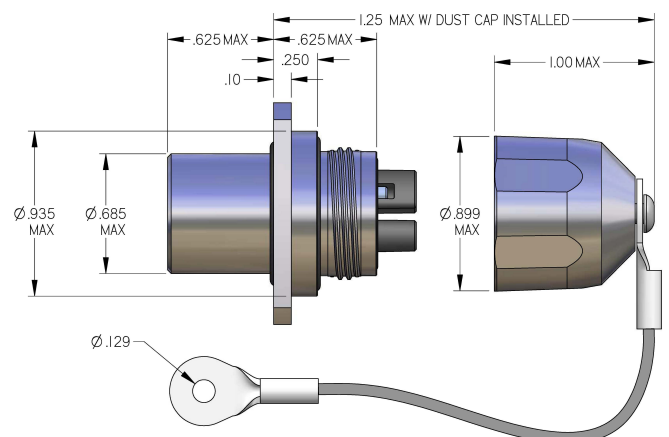

Amphenol Fiber Systems International, Inc. | 1300 Central Expressway N, Suite 100 Allen, TX 75013

Phone: (214) 547-2400 | Email: sales@fibersystems.com | Website: amphenol-fsi.com

Amphenol Fiber Systems International (AFSI), a division of Amphenol Military & Aerospace Operations (AMAO), is the largest manufacturer of harsh environment fiber optic cable assemblies & connectors in the world. Visit AMAO at amphenolmao.com.

mTACH6000 Panel Cutout:

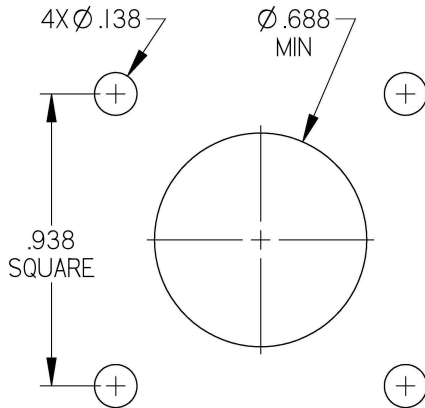

mTACH1000 Product Drawing:

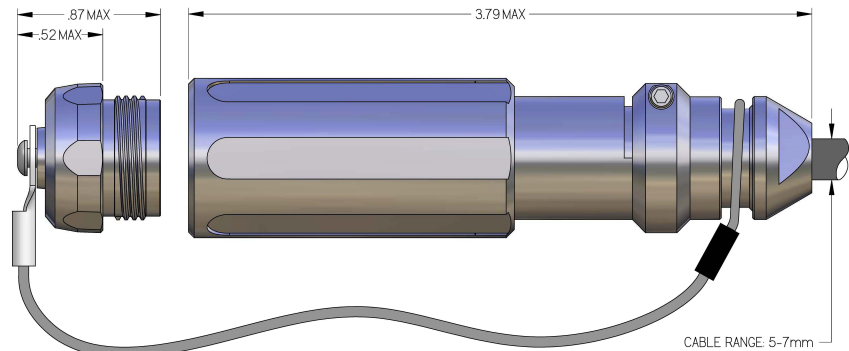

mTACH6000 Ordering Information:

mTACH8000 Receptacle, Jam Nut:

- mTACH1000 A1 Plug
 Dust Cap
 1 = Hermaphroditic, same material/finish as connector
 2 = Hermaphroditic, black plastic
 3 = Male, same material/finish as connector
 4 = Male, black plastic
- Connector Material & Finish
 3 = 6061-T6 Alum, gloss black hard anodized PTFE
 7 = 6061-T6 Alum, natural hard anodized PTFE
 C = 303 stainless, passivated

- mTACH6000 A1 Flange Mount Receptacle
 Dust Cap
 1 = Female, same material/finish as connector
 2 = Female, black plastic
- Connector Material & Finish
 3 = 6061-T6 Alum, gloss black hard anodized PTFE
 7 = 6061-T6 Alum, natural hard anodized PTFE
 C = 303 stainless, passivated

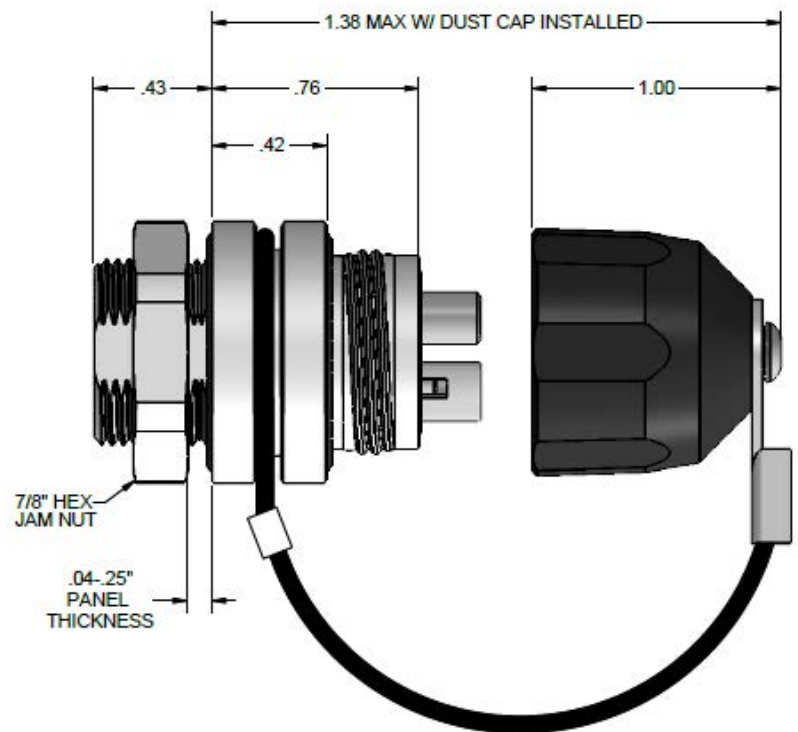

mTACH8000 Panel Cutout:

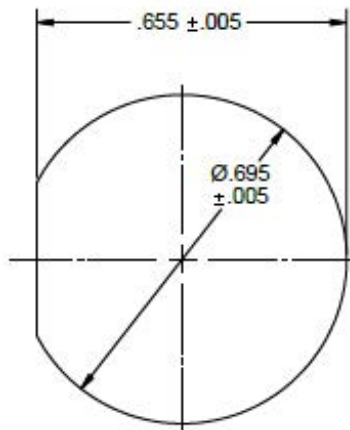

PANEL CUTOUT

mTACH8000 Insert Cap:

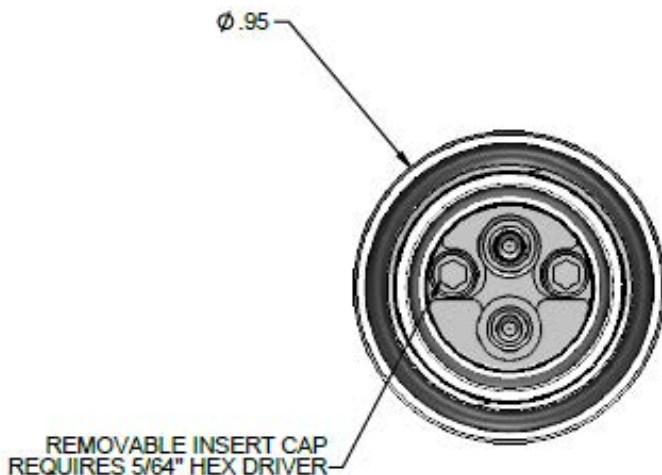

How to Order :

For more information on how to order or to obtain a price quote on any of our mTACH products, please call us at 800-472-4225. For international calls please dial 214-547-2400 or e-mail us at info@fibersystems.com.



About Amphenol Fiber Systems International :

Amphenol Fiber Systems International (AFSI) designs, manufactures, markets and supports reliable and innovative fiber optic interconnect solutions that withstand the harsh environments of military, oil & gas, mining and broadcast applications. After more than two decades in business, AFSI continues to uphold its position as a global leader in fiber optic interconnect components and systems such as termini, M28876, MIL-ST, TFOCA and the TFOCA-II® connector, which AFSI developed and patented.

AFSI has delivered millions of fiber optic connectors in more than 34 countries. Whenever there is a need for superior, cost-effective fiber optic systems and products that will stand up to demanding operating environments, you can rely on AFSI for engineering know-how, top-quality products and expert technical support.

Visit www.amphenol-fsi.com for more information.

Amphenol Fiber Systems International, Inc. | 1300 Central Expressway N, Suite 100 Allen, TX 75013

Phone: (214) 547-2400 | Email: sales@fibersystems.com | Website: amphenol-fsi.com

Amphenol Fiber Systems International (AFSI), a division of Amphenol Military & Aerospace Operations (AMAO), is the largest manufacturer of harsh environment fiber optic cable assemblies & connectors in the world. Visit AMAO at amphenolmao.com.