

Ethernet Connection System



FEATURES

The MTRJ Field offers an easy system to upgrade from a standard to an environmental MTRJ.

- Sealed against fluids and dust (IP67)
- Shock, Vibration proof,
- No cabling operation in field and no tools required for installation

APPLICATIONS

Data acquisition and transmission in Harsh Environment

- Railways
- Base Station
- Military communication
- Navy

With the patented RJStop[®] system you can use a standard MTRJ patchcord in a metallic plug which will protect it from shocks, dust and fluids. No hazardous field cabling.

This metallic plug is connected into a receptacle, using a Tri Start Thread coupling mechanism (MIL-DTL-38999 series III type) with anti-decoupling device for high vibrations.

Optical performance :

- Number of Channel : 1/2/4
- typical Insertion Loss : 0,5db in MM
- Durability 500 mating/unmating cycles (changes for <0,2 db)

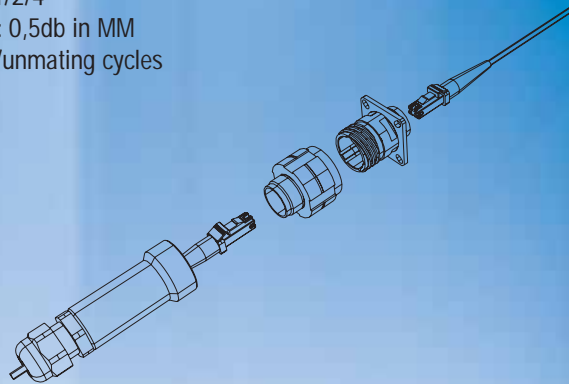

MTRJ FIELD TV

Transform your MTRJ patchcord into an Environmental Connector

Amphenol

Fiber Optic Solutions

MTRJ FIELD TV

LINE DRAWINGS (dimensions in mm)

• Plug (MIL DTL 38 999 series III Size 13)

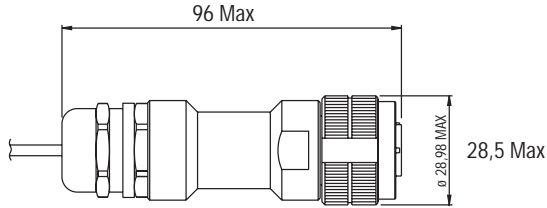

• Receptacle (MIL DTL 38 999 series III Size 13) with backshell

Square flange receptacle with backshell

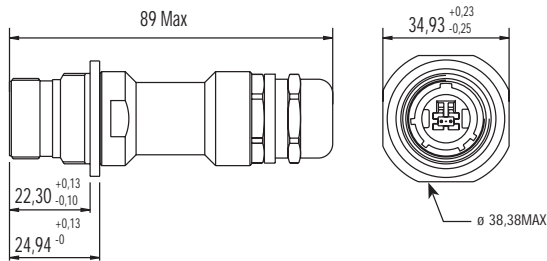

Jam Nut receptacle with backshell

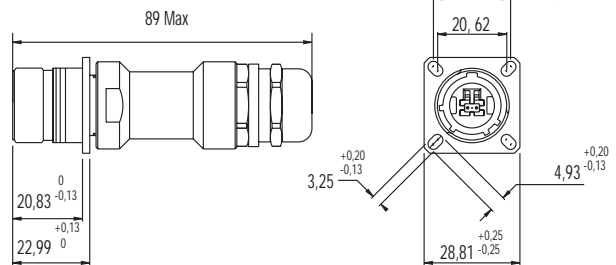

• Square Flange Receptacle (MIL DTL 38 999 series III Size 13)

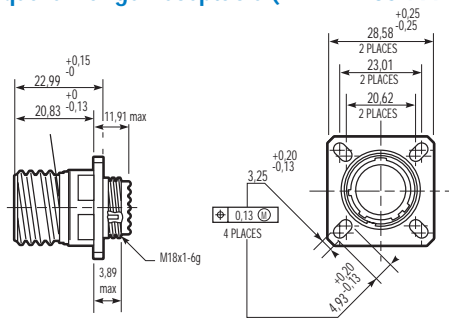

Panel Drilling

Square flange receptacle rear panel mounting

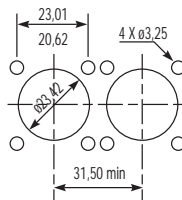

Square flange receptacle front panel mounting

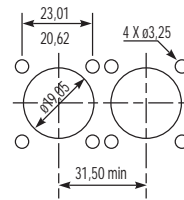

• Jam Nut Receptacle (MIL DTL 38 999 series III Size 13)

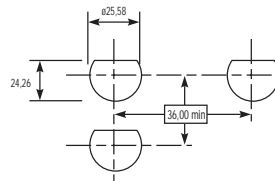
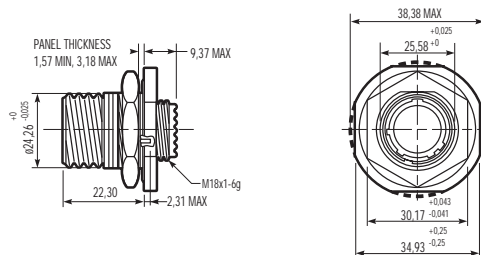

Panel Drilling
Jam nut receptacle rear panel mounting

• Protective caps

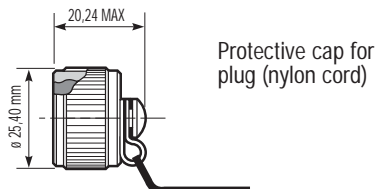

Protective cap for plug (nylon cord)

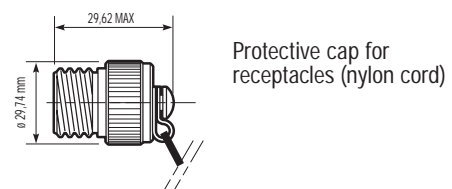

Protective cap for receptacles (nylon cord)



MTRJ FIELD ORDERING INFORMATIONS:

Serie:	MTRJ	F	TV	6M	C	G	M
MTRJ Field TV _____							
Shell type _____							
6 : Plug with metal backshell, plastic PG clamp							
6M : Plug with metal backshell and metal PG clamp							
2 : Square flange receptacle							
2PE : Sq. flange, metal backshell and plastic PG clamp							
2PEM : Sq. flange, metal backshell and metal PG clamp							
7 : Jam nut receptacle							
7PE : Jam nut, metal backshell and plastic PG clamp							
7PEM : Jam nut, metal backshell and metal PG clamp _____							
Cable type _____							
C : Mini round cable 2,8 mm							
D : Flat duplex cable 1,6 mm							
S : Duplex zipcord 1,6 mm							
O : Receptacle without backshell							
T : Mini round cable 2,8 mm or Flat duplex cable 1,6 mm or Duplex zipcord 1,6 mm _____							
Shell finish _____							
N : Nickel plated							
G : Olive drab cadmium plated							
B : Bronze _____							
Polarization _____							
N : Normal							
A, B, C, D, E _____							

DUST CAP ORDERING INFORMATIONS

CAP Series	B	EC	N	TV	W	13
Protective cap type _____						
EC : For square flange receptacle						
ER : For jam nut receptacle						
F : For plug _____						
Wire type _____						
N : Nylon cord						
Blank : Metallic chain _____						
TV : Series _____						
Shell finish _____						
B : Bronze						
F : Electroless nickel plated, aluminium version						
W : Olive drab cadmium plated, aluminium version _____						
Corresponding connector shell size : 13 _____						

Requested information to order MTRJ Field Patchcord

Plug MTRJ : Male /Female
 Type of fiber : 50/125, 62,5/125, 9/125
 Patchcord length : ex 10.5m
 Drawing : description of the product

Contact us for other configuration

Dismounting Tool Ordering Informations

MTRJFTV DM TOOL

NORTH AMERICA

AMPHENOL Pcd, Inc.

2 Technology Drive
Peabody, MA 01960
Telephone: 1-978-532-8800
Fax: 1-978-532-6800

AMPHENOL AEROSPACE OPERATIONS AMPHENOL INDUSTRIAL OPERATIONS

40-60 Delaware Street
Sidney, New York 13838-1395 - USA
Telephone: 1-607-563-5011
Fax: 1-607-563-5157

AMPHENOL BACKPLANE SYSTEMS

18 Celina Avenue
Nashua, New Hampshire 03063 - USA
Telephone: 1-603-883-5100
Fax: 1-603-883-0171

AMPHENOL CANADA CORPORATION

20 Melford Drive - Scarborough, Ontario M1B 2X6
Canada
Telephone: 1-416-291-4401 Fax: 1-416-292-0647
1870 boul. des Sources, Suite 204
Pointe Claire, Quebec H9R 5N4 - Canada
Telephone: 1-514-630-7242 ext. 225
Fax: 1-514-630-7697

AMPHENOL FIBER OPTIC PRODUCTS- RICHARDSON OPERATION

1778 North Plano Road, Suite 212
Richardson, Texas 75081
Telephone: 1-972-744-9801
Fax: 1-972-744-9022

AMPHENOL FSI

1300 Central Expwy N, Suite 100
Allen, TX 75013 U.S.A.
Toll-Free: 800-472-4225 - Fax: 214-547-9344
info@fibersystems.com

EUROPE

AMPHENOL SOCAPEX

MIL-AERO & INDUSTRIAL Business Unit
948 Promenade de l'Arve - B. P. 29
74311 Thyez Cedex - France
Telephone: 33-4-5089-2800
Fax: 33-4-5096-1941

AMPHENOL LIMITED WHITSTABLE

Thanet Way, Whitstable - Kent, CT5 3JF
United Kingdom
Telephone: 44-1227-773-200
Fax: 44-1227-276-571

AMPHENOL LIMITED NOTTINGHAM

Unit D1 Crossgate Drive, Queens Drive Industrial
Estate - NG2 1LW - Nottingham - United Kingdom
Telephone: 44-1159-866-200
Fax: 44-1159-866-212

AMPHENOL AIR LB GmbH

Am Kleinbahnhof 4 - 66740 Saarlouis Germany
Telephone: 49-6831-981-00
Fax: 49-6831-981-030

AMPHENOL ITALIA

Via Barbaiana n. 5, 20020 Lainate - Milano - Italy
Telephone: 39-293-55-03-71
Fax: 39-348-361-7249

AMPHENOL IBERICA

C/Calderon de la barca, 3 4A, 28 100 Alcobendas,
Madrid - Spain
Telephone: 34-91-654-83-52
Fax: 34-91-640-73-07

AMPHENOL SCANDINAVIA

Snosvangen 14 13466 Ingaro - Sweden
Telephone: 46-8-571-423-90
Fax: 46-8-571-423-89

AMPHENOL BENELUX

Zadelmaker 121 NL-2401 PD Alphen aan den Rijn
The Netherlands
Telephone: 31-172-444-903
Fax: 31-172-240-254

AMPHENOL CENTRAL EUROPE

Topolowa 13, 41 600 Swietochlowice - Poland
Telephone: 48-32-3484-201 - Fax: 48-32-3484-202

AMPHENOL EUROPEAN SALES OPERATIONS

Hoofdveste 19 - 3992 DH Houten - The Netherlands
Telephone: 31-30-635-8000 - Fax: 31-30-637-7034

ASIA

CHINA (FOP)

3rd Floor, The 4th Ind. District of Ind.
Headquarters Dong Keng Road, Gong Ming Town
Shenzen 518132, Guangdong Province - PR China
Telephone: 86-755-717-7945
Fax: 86-755-717-7622

AMPHENOL TAIWAN CORPORATION

No. 116, Lane 956, Zhong Shan Road
Taoyuan City, R. O. C., 330 - Taiwan
Telephone: 886-3-379-5677
Fax: 886-3-360-7259 Sales/CS/Eng./QA/MIS

AMPHENOL EAST ASIA LIMITED

2201 Railway Plaza, 39 Chatham Road South
Tsmishatsui, Kowloon - Hong Kong
Telephone: 852-2699-2663
Fax: 852-2691-1774

AMPHENOL INTERCONNECT INDIA PRIVATE LIMITED

105 Bhosari Industrial Area - Pune 411 026 - India
Telephone: 91-20-712-0363/0463/0155
Fax: 91-20-712-0581

AMPHENOL JAPAN MIL/AERO INDUSTRIAL

689-1, Iseochi, Ritto-shi Shiga 520-3044 - Japan
Telephone: 81-77-553-8501
Fax: 81-77-551-2200

AMPHENOL DAESHIN

558 Sosa, SongNea
Bucheon-city, Kyunggi-Do - Korea 420-130
Telephone: 82-32-610-3800
Fax: 82-32-673-2507/665-6219

REST OF THE WORLD

AMPHENOL MEXICO

Prolongacion Reforma 61-6 B2
Col. Paseo de las Lomas - C.P. 013130 Mexico
Telephone: 52-55-5258-9984
Fax: 52-55-5081-6890

AMPHENOL SOUTH AFRICA

30 Impala Road
2196 Chislehurst-Sandton - South Africa
Telephone: 27-11-783-9517 - Fax: 27-11-783-9519

BAR TEC LTD

4 Hagavish St, PO Box 279 - Kfar Saba 44102 -
Israel
Telephone: 972-9-767-4097
Fax: 972-9-767-4324

GESTAS

34630, Besyol Londra Asfalti
Florya is Merkezi Kat.2 - Sefakoy / Istanbul - Turkey
Telephone: 90-212-624-52-29
Fax: 90-212-599-30-68

AMPHENOL ARGENTINA

"Av. Callao 930 2do piso Oficina B "Plaza"
C1023" - AAP Buenos Aires - Argentina
Telephone: 54-11-4815-6886
Fax: 54-11-4814-5779

TFC SOUTH AMERICA

BUENOS AIRES, ARGENTINA

Local Sales Office - Tucuman 540 - Suite 28 "C"
C1049AAL- Buenos Aires - Argentina
Telephone: 54-11-4325-3471
Fax: 54-11-4327-1339

AMPHENOL AUSTRALIA PTY LIMITED

2 Fiveways Blvd., Keysborough
Melbourne, Victoria 3173 - Australia
Telephone: 61-3-8796-8888
Fax: 61-3-8796-8801

AMPHENOL DO BRAZIL

Rua Diogo Moreira, 132, 20 andar, rooms 2001-2-3
CEP: 05423-010 Sao Paulo SP - Brazil
Telephone: 55-11-3815-1003
Fax: 55-11-3815-1629

Amphenol reserves the right to change the content of this document without prior notice

Amphenol
Fiber Optic Solutions

Realisation : wagen:studios - Steven Kilgallon - 01/2004
Printed in France by MenloPark

For more informations, please consult our website :
www.amphenol-fiberopticsolutions.com

DOC-000507-ANG-A