



### About the FSHDM Connector

Amphenol Fiber Systems International (AFSI) has announced the latest addition to its Harsh Environment product portfolio. The FSHDM Hermaphroditic Duplex Miniature is ideal for a variety of applications in Harsh Environments.

FSHDM is hermaphroditic which allows the daisy chaining of cable assemblies therefore eliminating the need for polarising the assemblies or in-line adaptors. There is a bayonet locking mechanism, it is sealed and ensures high environmental and optical performance in a variety of applications ranging from land tactical to broadcasting applications.

The FSHDM is offered in aluminium with hard black anodised finish, providing good anti corrosion properties and RoHs compliancy. The bayonet coupling offers simplistic and quick mating/demating. This connector series is compatible with tactical cable styles for the plug and simplex ruggedised cable for the receptacle both in multimode and singlemode.



### KEY FEATURES

- Hermaphroditic
- Multimode and Singlemode available
- Ø2.5mm ceramic ferrule
- Lightweight, small footprint
- Artic style grip
- Low insertion loss
- IP 68 sealing
- Removable front receptacle shell for cleaning insitu
- Removable plug monobloc for ease of cleaning
- >500 cycles mating durability
- Operating temperature -55C to + 125C

### APPLICATIONS

- Military Land Communications
- Broadcast

AFSI designs, manufactures, markets and supports reliable and innovative fiber optic interconnect solutions that withstand the harsh environments of military, oil & gas, mining and broadcast applications. After more than two decades in business, AFSI continues to uphold its position as a global leader in fiber optic interconnect components, systems and solutions

AFSI has delivered millions of fiber optic connectors worldwide. Whenever there is a need for superior fiber optic systems and products that will stand up to demanding operating environments, you can rely on AFSI for engineering know-how, quality products and expert technical support.

For more information about AFSI, please visit our website at [www.amphenol-fsi.com](http://www.amphenol-fsi.com)

## FSHDM SERIES – RUGGED FIBER OPTIC CONNECTORS

### PERFORMANCE

Insertion Loss	<0.6dB with 62.5/125
Repeatability	<0.15dB
Fiber Types	9/125, 50/125 & 62.5/125
Temperature Range	-55 - +85 Deg C
Vibration	10Hz to 5000Hz
Shock	As per EN2591 Test FD2 D2 Method A
Durability	>500 mating cycles
Material	Aluminium
Finish	Hard Anodised, Black in Colour
RoHs	Compliant

### FSBDC SERIES ORDERING INFORMATION

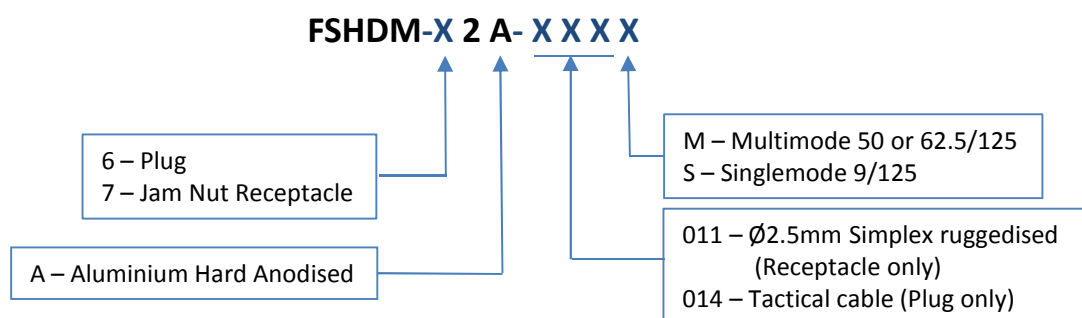

FOR MORE INFORMATION PLEASE CONTACT THE FACTORY

**Amphenol**  
MILITARY & AEROSPACE

Specifications subject to change without notice.

© 2016 Amphenol Fiber Systems International. All rights reserved.

Amphenol Fiber Systems International  
1300 Central Expressway North, Suite 100  
Allen, TX 75013

Phone: 214.547.2400 – 800.472.4225

Fax: 214.547.9344

[www.amphenol-fsi.com](http://www.amphenol-fsi.com)