

**Part Number Information**

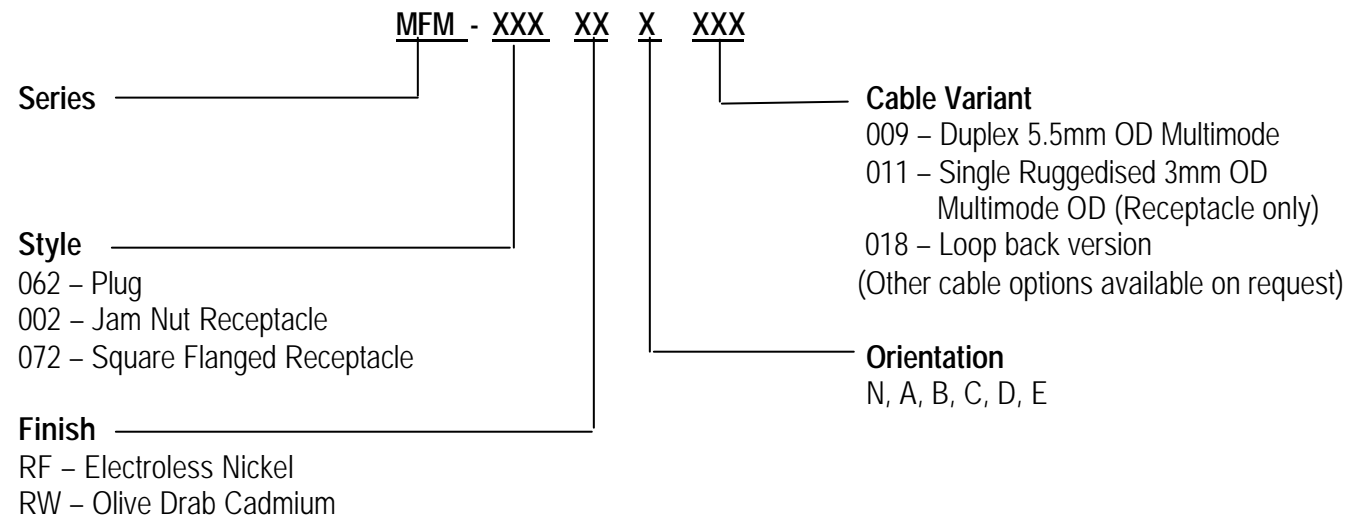

Sub-Assemblies

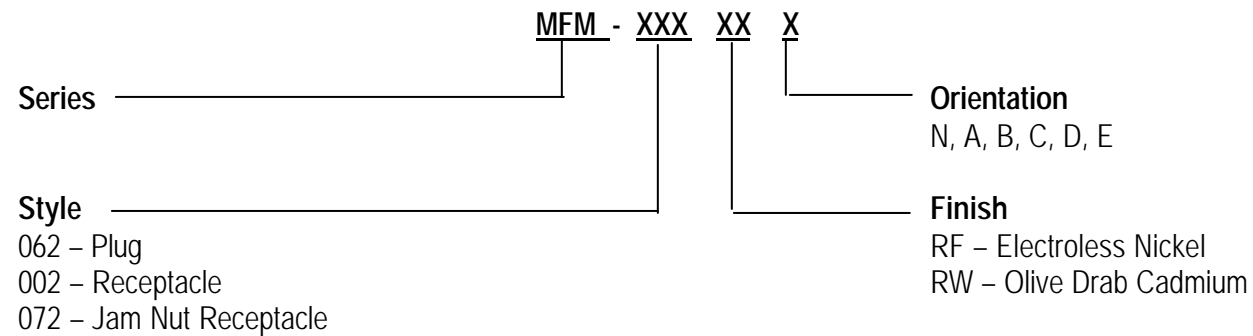
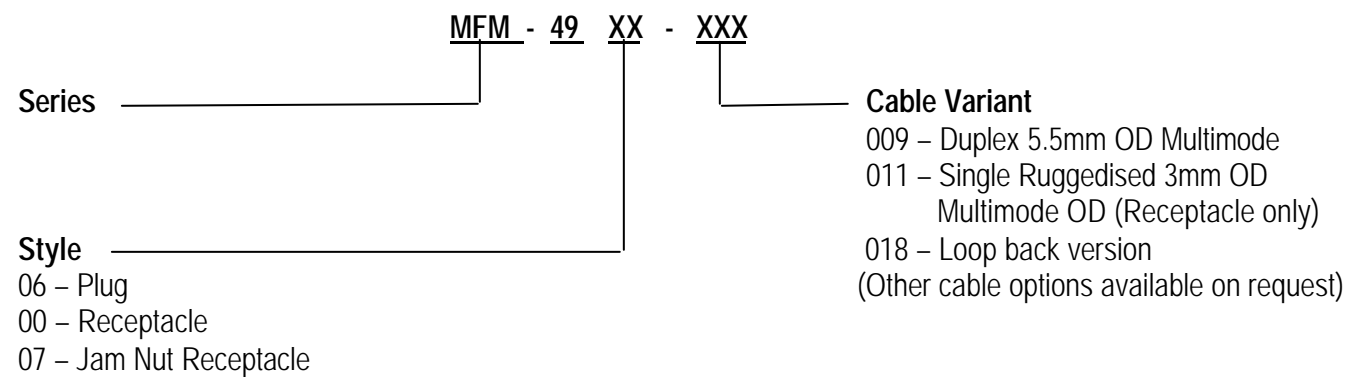

**Notice:** Products are sold subject to Amphenol's conditions of sale ("the standard conditions"). All specifications and statements contained herein are believed to be correct at the time of printing but no representation or warranty, express or implied, is given as to any specification or statement contained herein. Product specifications including performance characteristics are typical only and subject to deviation. Specifications are also subject to change without notice. Users should not assume that all safety measures are indicated or that other measures may not be required. No representation or warranty, express or implied, is given that any use of products (including any stated or suggested use) does not infringe any patent, registered design or other third party rights and no stated or suggested use of products can be taken to recommend any such infringement.

# Amphenol

## MFM Military Fibre Optic Miniature



- The MFM uses ceramic ferrule technology, with a ceramic alignment sleeve to reduce insertion loss
- Based on a Size 13 38999 Series III connector with keyway polarisation
- One piece monobloc termination construction for ease of cleaning
- Both shells and ferrules are keyed for optimum repeatability
- Environmentally sealed when mated
- Simple termination procedure
- Interchangeable cable sub assembly with other Amphenol product series

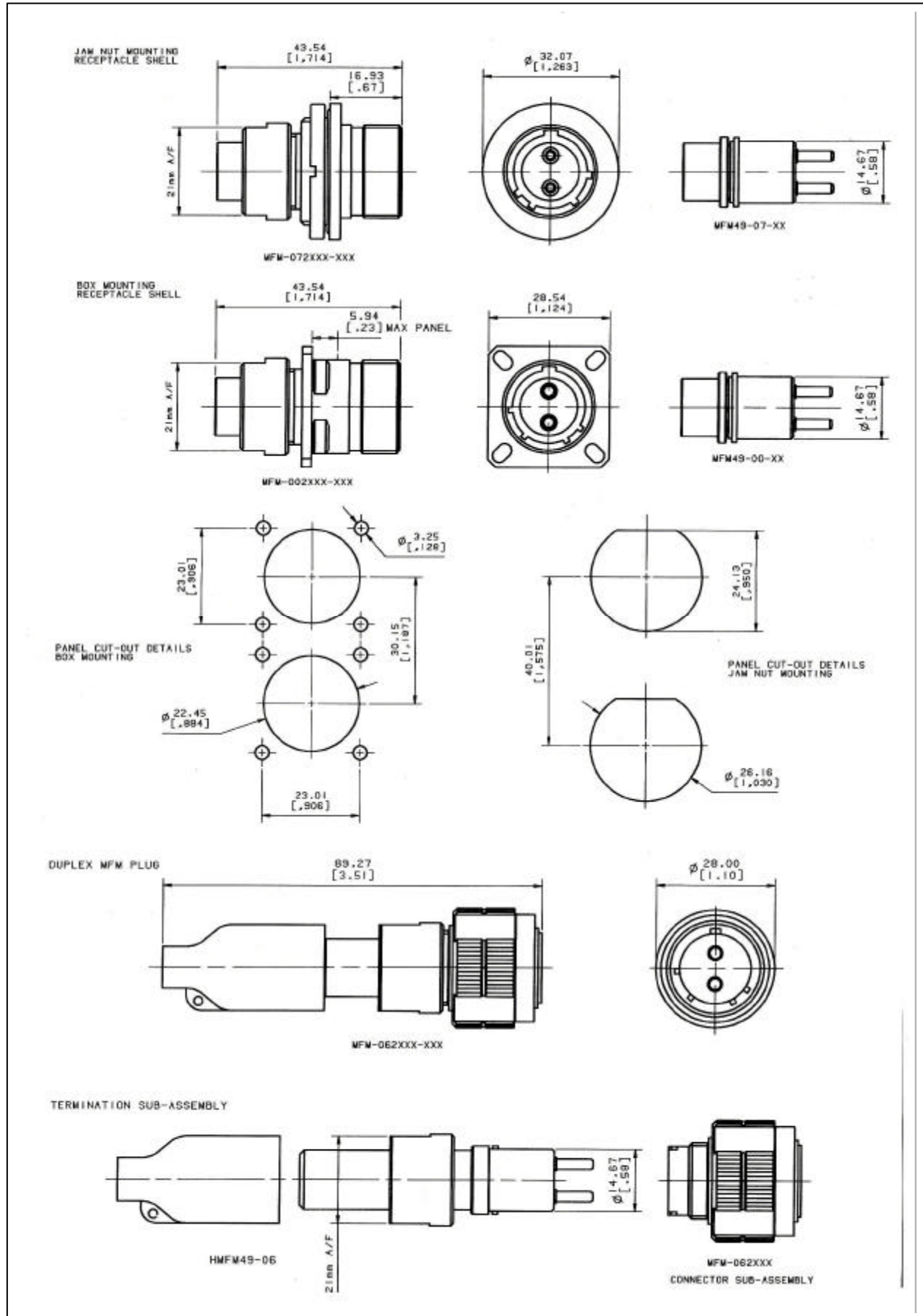

Performance

Optical	
Attenuation	Typically 0.3dB with 62.5/125 cable
Repeatability	>0.15dB
Fibre Types	50/125      62.5/125
	85/125      100/140
	200/280
Termination Method	Epoxy / Polish

Environmental	
Temperature Range	-55°C to +125°C Cable dependent

Mechanical	
Durability	>500 matings
Materials	Shell : Electroless Nickel or Olive Drab plated
	Ferrule : Zirconia Ceramic
	Alignment Sleeve : Zirconia Ceramic
	Seals : Silicone

Termination Tooling	
Basic Kit	927 – 100 – 3000
Duplex MFM Add on Kit	927 – 100 – 3200
Consumable Pack	927 – 100 – 6000

Other items of tooling may be ordered separately – please consult factory.

Protective Caps	
Plug Protective Cap	10 – 553998 – 139 (860)
Receptacle Protective Cap	10 – 553970 – 139 (860)

