

AFSI Fiber Optic Reels

About Fiber Optic Reels

Amphenol Fiber Systems International (AFSI) offers the rugged, deployable ARES (Amphenol Reel Enhanced System) reel for tactical fiber optic network applications. The unit is made with reinforced glass nylon providing a rust-resistant, lightweight and durable reel for storing and deploying fiber optic cable assemblies. Integrated slots on the reel allow them to be stacked together for storage and transit. The ARES reel also has separate payout and storage areas allowing the operator to deploy cable needed rather than the entire stored length.

ARES Fiber Optic Reel Specifications

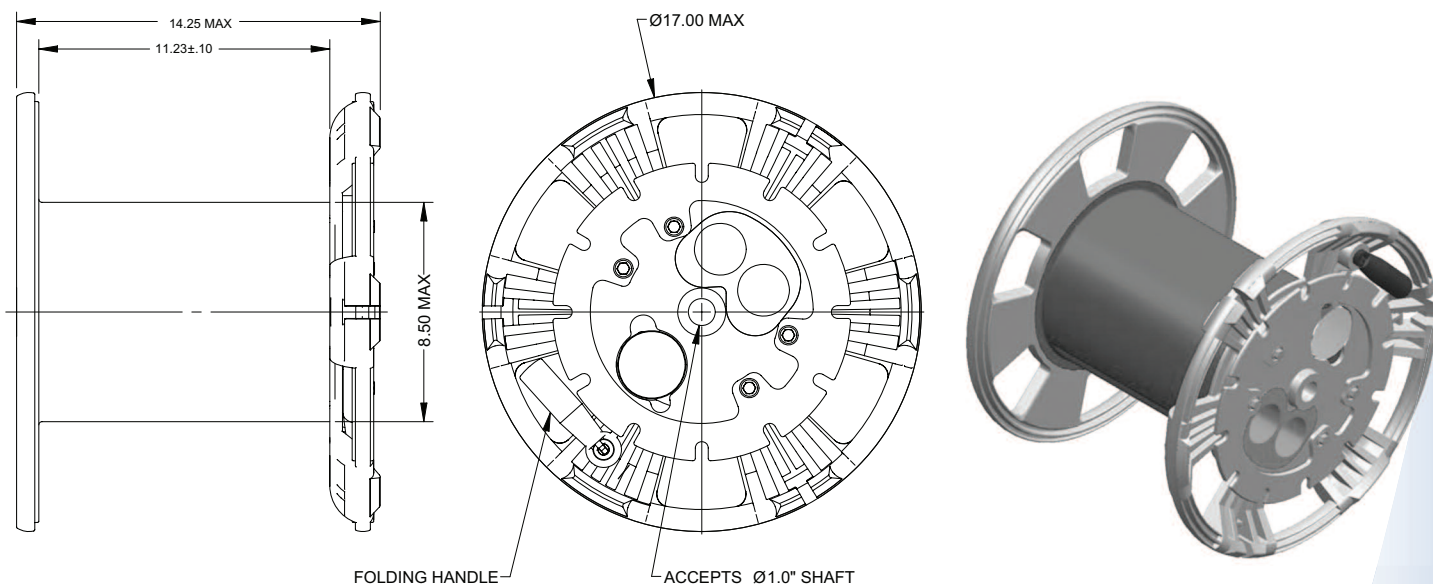

AFSI's ARES reel comes in a variety of sizes to support multiple cable lengths and types. In addition, cleaning kits can be specified to support all popular harsh environment connectors including AFSI's TFOCA, TFOCA-II®, TFOCA-III®, TACBeam and Pierside. Finally, AFSI offers a suite of transit cases and backpacks as optional accessories.

Features & Benefits

- Integrated fiber optic cleaning kit allows connector maintenance during deployment
- Separate payout and storage areas allows the user to deploy what they need instead of the entire payload
- Retractable crank, internal connector storage spaces and interlocking slots allow ARES to be easily stacked, stored and transported.
- Rust-resistant, lightweight construction
- Reel frame, transit case and manpack options available

Applications

- US Army and Marine Corps Tactical Deployments
- Deployable Broadcast Networks
- Mobile Tactical Shelter Systems
- Disaster Recovery

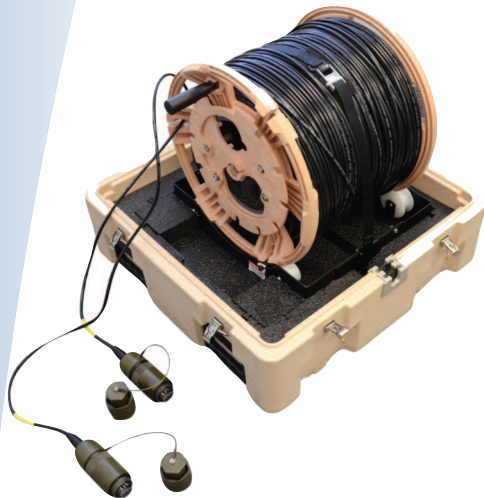

How to Order

To order or to obtain a price quote on our AFSI Fiber Optic Reels, call toll free (US only) at 800.472.4225, international calls please use 1.214.547.2400 or e-mail sales@fibersystems.com.

Ordering Nomenclature

ARES-XXXX-X-X

CAPACITY

0100 = 100M
0300 = 300M
0500 = 500M
1000 = 1000M

COLOR

G = GREY
D = DESERT SAND

CLEANING KIT

1 = TFOCA II®
2 = TFOCA III®
3 = TFOCA
4 = PIERSIDE
5 = TACBEAM

ACCESSORIES

ARES F5 = REEL FRAME WITH 500M CAPACITY
ARES R1 = REEL STAND WITH 100M CAPACITY

About Amphenol Fiber Systems International

Amphenol Fiber Systems International (AFSI) designs, manufactures, markets and supports reliable and innovative fiber optic interconnect solutions that withstand the harsh environments of military, oil & gas, mining and broadcast applications. After more than a decade in business, AFSI continues to uphold its position as a global leader in fiber optic interconnect components and systems such as termini, M28876, MIL-ST, TFOCA and the TFOCA-II® connector, which AFSI developed and patented.

AFSI has delivered millions of fiber optic connectors in more than 34 countries. Whenever there is a need for superior, cost-effective fiber optic systems and products that will stand up to demanding operating environments, you can rely on AFSI for engineering know-how, top-quality products and expert technical support.

Visit www.fibersystems.com for more information.

